

3M™ Betafine™ PBG Series

Pleated Polypropylene Graded-Porosity Filter Cartridges

Filters For Food and Beverage Applications

The Betafine PBG series filter cartridge represents a major advance in pleated filter technology and performance. Building on 3M Purification Inc.'s history of filter design innovation, this absolute-rated, graded-porosity 100% polypropylene pleated filter cartridge features Advanced Pleat Technology (APT) that increases the usable filtration surface area while maintaining standard industrial cartridge dimensions. The result is a filter cartridge that dramatically enhances service life.

Features & Benefits

Advanced pleat technology construction for high surface area as compared to competitive filters

- Higher product throughputs for prolonged service life
- Lower total filtration operating costs
- Lower pressure drops for higher flow rates

Absolute-rated filter performance

- Higher product quality and yields

Graded-porosity multi-layer filter media

- Capture of contaminant throughout the filter media to help maximize filter life
- Higher contaminant holding capacity

Backflushable, Polypropylene cartridge components

- Very low extractable levels for optimum filtrate purity
- Broad compatibility with solvents and cleaning solutions



Applications

Betafine PBG series filter cartridges are ideal for a wide array of prefiltration and clarification applications where reliability and economy are critical. Suggested applications include:

Food and Beverage Service

- Protection and longevity of expensive membrane final filters
- Final particle control
- Food fermentation feeds, intermediates and fermentation clarification
- Blending water filtration
- Cleaning fluids
- Solvent streams, air and gas prefiltration and final filtration

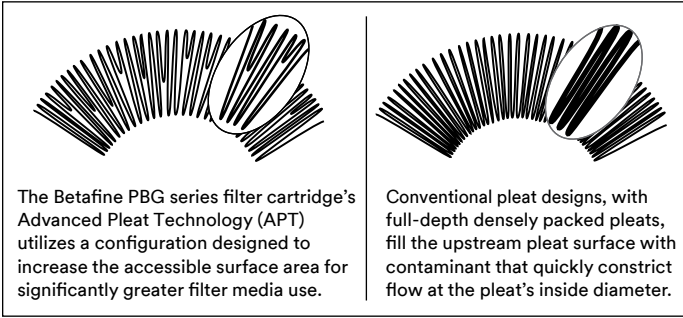
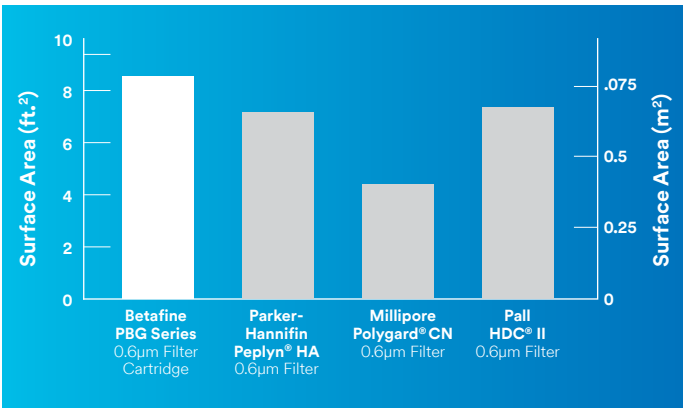

Figure 1. Advanced Pleat Technology vs. Conventional Pleat Design



Graph 1. Competitive Comparison: Surface Area

	Pall HDC® 0.6µm Filter	Betafine PBG Series 0.6µm Filter Cartridge
Typical Surface Area	7.0 ft ²	8.8 ft ²
Flow @ 1 psid	1 gpm	3.3 gpm
Number of Filter Cartridges Needed for a Flow Rate of 50 gpm	12 – 40"	4 – 40"
Housing Size	12-around x 40"	4-around x 40"

Table 1. Competitive Comparison: Flow Rate of 50 gpm

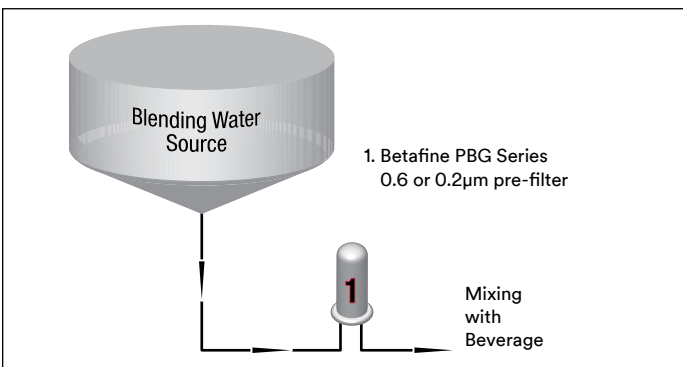

Figure 2. Blending Water with Betafine PBG Series Filter Cartridges

Advanced Pleat Technology

The service life of a pleated cartridge is often dictated by the accessible surface area. Conventional pleated filters may offer a large gross surface area, but when the media is packed too tightly into the cartridge, only part of the surface area is usable resulting in both flow restrictions and limited contaminant holding capacity. The “blind” or unusable area commonly occurs near the inside diameter (see Figure 1) where the pleats are packed most tightly. The Betafine PBG series filter cartridge is manufactured using a staggered pleat configuration that, when combined with a novel support material, provides more open space between the pleats. The APT staggered pleats with increased open area allow for greater contaminant loading between pleats at the inside diameter, while the reduced length pleats take advantage of existing open space closer to the filter's outside diameter. The result is a fully used surface area that provides superior service life.

Betafine PBG Series Filter Cartridges For Food and Beverage Service

Betafine PBG series filter cartridges meet the requirements for today's food and beverage processing needs. All materials of construction comply with the requirements of the Food and Drug Administration's (FDA) Code of Federal Regulations (CFR), Title 21 parts 170–199 for contact with food. The filter cartridge can be autoclaved, steamed-in-place (*in situ*), and sanitized with hot water. The durable polypropylene construction provides excellent performance in all food and beverage filtration applications.

- Backflushable — Betafine PBG series filter cartridge applications can be designed with a variety of methods to extend service life. Combined with hot water sanitation or other in-line cleaning procedures, backflushing Betafine PBG series filter cartridge systems can extend service life significantly.

Protection of Final Membranes

Beverage bottlers frequently employ membrane filter cartridges to achieve microstability without heat pasteurization. Typical retention ratings for the final filter are 0.45 µm or 0.65 µm. The Betafine PBG series filter cartridge's absolute retention, graded-porosity structure and large surface area are ideal for prefiltration protection of final sterilizing membranes. By removing contaminants before the final filter, the service life of expensive membrane filter cartridges are extended significantly.

The Betafine PBG Series Filter Cartridge Advantage

Today's demanding beverage consumer insists on high quality, turbidity-free juices, teas, and fruit drinks. Blending water needs to be free of microscopic particulate that can cause haze and undesirable cloudiness in the final beverage. With the unique APT design, systems designed with Betafine PBG series 0.6µm absolute rated filter cartridges result in significantly smaller filter housing and fewer installed filters when compared to competitors (Table 1).

For the same initial differential pressure, bottlers using Betafine PBG series filter cartridges require a housing only one fourth the size needed for Pall HDC filters. This results in significantly lower capital investment for filtration equipment and fewer cartridges to purchase. The bottom line — more cost effective filtration.

Graded-porosity — the Key to Longer Life

The Betafine PBG series filter cartridge’s graded-porosity media structure reduces particles sequentially by size — the larger particles by the more open, outer medium and the smaller particles by the tighter, inner medium (see Figure 3). The outer medium acts as a prefilter, while the inner provides the absolute removal specified by the cartridge rating. This construction effectively spreads the contaminant through the depth of the filter media resulting in high contaminant capacity with lower pressure drop for longer service life as compared to competitive filters.

Chemical Compatibility

Polypropylene construction provides chemical compatibility in many demanding process fluid applications. Compatibility is influenced by process operating conditions; in critical applications, cartridges should be tested under actual conditions to determine the correct selection.

Flow Characteristics and Sizing Options

Flow vs. differential pressure for clean water is depicted in Graph 2 for each Betafine PBG series filter cartridge grade. Ideally, filter systems should be sized at an initial differential pressure of 0.5 to 1 psid (0.04 to 0.07 bar). Low flow rates further extend the life of the filter system. In most applications, doubling the filter area (reducing the flow rate per unit area by one-half) results in two and one-half times the throughput.

- Reduced cartridge change-out frequency — for a given process flow rate, the graded-porosity structure and maximum filter area decrease filter cartridge change-out frequency by 30 to 50 percent or more depending on the application.
- Reduced filter housing costs — for new applications, the low pressure drops of the Betafine PBG series filter cartridge allow smaller or fewer housings to be specified. Fewer filter cartridges and smaller housings help provide lower capital and consumables costs, year after year.

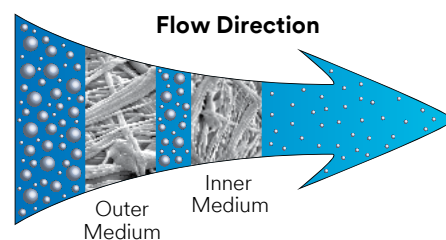
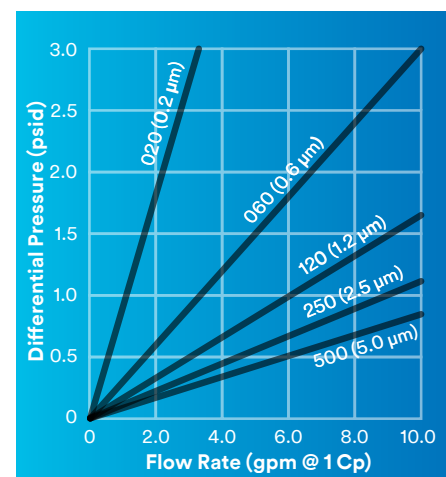

Figure 3. Graded-Porosity Reduces Particles Sequentially by Size



Graph 2: Clean Water Flow per 10" Betafine PBG Series Filter Cartridge at Ambient Temperature (20°C)

Operating Parameters & Specifications

Material of Construction		
Filter Media	Graded-Porosity Pleated Polypropylene	
Media Support Layers	Polypropylene	
Inner Core, Outer Cage, End Cap Adapters	Polypropylene	
Gasket and O-ring Options	Silicone, EPR	
Adapter Support Ring	Stainless Steel	
Filter Cartridge Dimensions		
Filtration Surface Area	060, 100, 120, 250	8.8 ft. ² (0.82m ²)
Filtration Surface Area	020	8.1 ft. ² (.75m ²)
Filtration Surface Area	500	8.6 ft. ² (0.80m ²)
Outside Diameter	2.80 in. (7.1cm)	
Nominal Length	10 in. (25.4cm), 20 in. (50.8cm), 30 in. (76.2)	
Operating Parameters		
		Specification
Maximum Operating Temperature	130°F (60°C) continuous, 175°F (80°C) short term	
Maximum Differential Pressure (Forward and Reverse)	60 psid (4 bar) @ 77°F (25°C)	

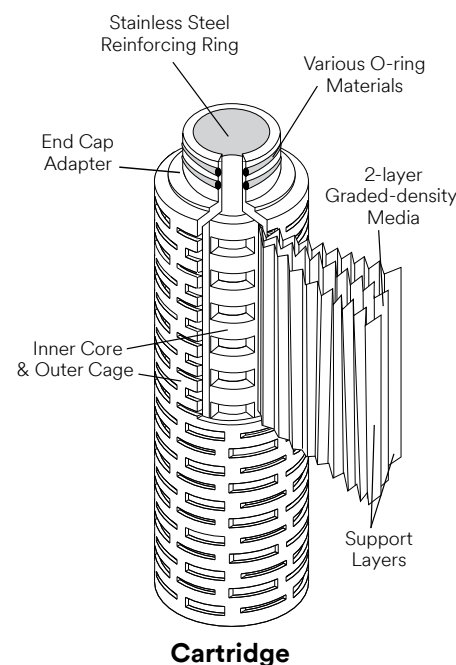

3M™ Betafine™ PBG Series Filter Cartridge Ordering Guide

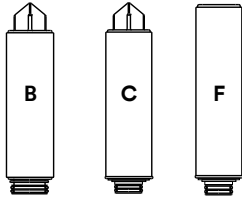
Cartridge Code	Grade Code/ Absolute Rating ¹ (µm)	Configuration	Length (Inches)	End-modification	Gasket/O-ring Material
PBG	020 – 0.2 060 – 0.6 120 – 1.2 250 – 2.5 500 – 5.0	B – Cartridge	01 – 10 02 – 20 03 – 30	B – 226 O-Ring & Spear C – 222 O-Ring & Spear F – 222 O-ring & Flat Cap 	A – Silicone C – EPR

¹ Retention ratings determined by 3M Purification Inc. test method TP. The 0.2µm rating has been extrapolated. For more information, contact your 3M Purification Inc. representative.

PLEASE NOTE: The Ordering Guide above is for reference only. Not all combinations are available. Please consult with your 3M Representative to determine the appropriate part number for your application.

Intended Use: 3M™ Betafine™ PBG Series Filter cartridges are intended for use in food and beverage filtration applications of aqueous fluids in accordance with the applicable product instructions and specifications. 3M Betafine PBG Series Filter cartridges are also intended for use with non-aqueous fluids where materials of construction are compatible. Since there are many factors that can affect a product's use, the customer and user remain responsible for determining whether the 3M product is suitable and appropriate for the user's specific application, including user conducting an appropriate risk assessment and evaluating the 3M product in user's application.

Restrictions on Use: 3M advises against the use of these 3M products in any application other than the stated intended use(s), since other applications have not been evaluated by 3M and may result in an unsafe or unintended condition. Do not use in any manner whereby the 3M product, or any extractable or leachable from the 3M product, may become part of or remains in a medical device, drug, cosmetic, supplement, infant formula; or in applications involving life-sustaining medical applications or prolonged contact with internal bodily fluids or tissues.

Technical Information: The technical information, guidance, and other statements contained in this document or otherwise provided by 3M are based upon records, tests, or experience that 3M believes to be reliable, but the accuracy, completeness, and representative nature of such information is not guaranteed. Such information is intended for people with knowledge and technical skills sufficient to assess and apply their own informed judgment to the information. No license under any 3M or third party intellectual property rights is granted or implied with this information.

Product Selection and Use: Many factors beyond 3M's control and uniquely within user's knowledge and control can affect the use and performance of a 3M product in a particular application. As a result, customer is solely responsible for evaluating the product and determining whether it is appropriate and suitable for customer's application, including conducting a workplace hazard assessment and reviewing all applicable regulations and standards (e.g., OSHA, ANSI, etc.). Failure to properly evaluate, select, and use a 3M product and appropriate safety products, or to meet all applicable safety regulations, may result in injury, sickness, death, and/or harm to property.

Warranty, Limited Remedy, and Disclaimer: Unless a different warranty is expressly stated on the applicable 3M product packaging or product literature (in which case such express warranty governs), 3M warrants that each 3M product meets the applicable 3M product specification at the time 3M ships the product. 3M MAKES NO OTHER WARRANTIES OR CONDITIONS, EXPRESS OR IMPLIED, INCLUDING, BUT NOT LIMITED TO, ANY IMPLIED WARRANTY OR CONDITION OF MERCHANTABILITY, FITNESS FOR A PARTICULAR PURPOSE, OR ARISING OUT OF A COURSE OF DEALING, CUSTOM, OR USAGE OF TRADE. If a 3M product does not conform to this warranty, then the sole and exclusive remedy is, at 3M's option, replacement of the 3M product or refund of the purchase price.

Limitation of Liability: Except for the limited remedy stated above, and except to the extent prohibited by law, 3M will not be liable for any loss or damage arising from or related to the 3M product, whether direct, indirect, special, incidental, or consequential (including, but not limited to, lost profits or business opportunity), regardless of the legal or equitable theory asserted, including, but not limited to, warranty, contract, negligence, or strict liability.

3M Filtrazione Industriale
ora fa parte di Solventum

www.Solventum.com

Distributore autorizzato in Italia:
www.vason.com

ENOLOGICA
VASON®
S.p.A.

Betafine and 3M are trademarks of 3M Company.
All other trademarks are the property of their respective owners.
©2024 3M Company. All rights reserved. Please recycle.
70-0202-3144-1 REV 224hb